

Reno World Development Plan Objects, Gestures and Regions by Major Milestone

F. Randall Farmer
November 15, 1994

Updated: January 16th, 1995
Jeffery Douglas, Lead Oracle

The Milestones:

α Alpha test: Testable viagateway/concetrator & local. 10s of users.

β Beta test: Connection via gateway interface. 100s of users. UI Freeze.

λ Limited Release: Dress rehearsal. Package done. 1000s of users.

τ Release: Ship to 10,000s of users.

\hat{o} Future Development: Not planned for Reno 1.0

Notes:

The resources (classes/regions) required are marked with the milestone symbol indicated above.

The class list is primarily derived from the Lucasfilm Habitat object list, the Fujitsu Habitat objects, and the 'Future Habitat Features' lists that have been circulating for the last 6 years. There are several new classes defined here as well.

One lesson learned from Habitat is that classes should be defined by function, instead of real-world names. This means that Reno has fewer classes of objects for the same functionality (i.e. class_bag and class_box have been folded together into the new class_container.)

Special UI features required for each class are in { } braces.

1 = Pullright Menus

2 = Contents Window

3 = Get text dialog

4 = Page Text Editor/Viewer

5 = Bitmap Image display (i.e. GIF)

6 = Textured Polygon display

7 = Text display in main window

8 = Display a scrolling choice list

9 = Trigger events (Client watches for an event, and spawns another)

Note: all of these potentially support buttons of the standard GUI types.

α class_avatar {1,2,8}
 α class_flat (formerly ground, sky, wall)
 α class_ghost {1,8}
 α class_head {2}
 α class_immobile_scenery (formerly bush, tree, plant ...)
 α class_knick_knack
 α class_magic (formerly wand, staff, gemstone, ring, amulet) {3}
 α class_region
 β 1 class_atm {1}
 β 1 class_container (formerly display_case, countertop, bag, box,chest, safe) {2,3 (combo)}
 β 1 class_document (paper, envelope, mailbox, book, plaque) {4, 8}
 β 1 class_door {3(combo)}
 β 1 class_glue
 β 1 class_head_accessories NEW
 β 1 class_key
 β 1 class_name_registrar NEW {3}
 β 1 class_pawn_machine
 β 1 class_seating (formerly chair and couch)
 β 1 class_sign (formerly sign and short_sign)
 β 1 class_spray_can
 β 1 class_teleport_booth {1,3}
 β 1 class_tokens {3}
 β 1 class_vendo_front
 β 1 class_vendo_inside
 β 2 class_body_changer (formerly sex_changer)
 β 2 class_elevator {2}
 β 2 class_picture (redefined to show a bitmap) {5}
 β 3 class_building (Duplicate?)
 β 3 class_event_driven_robot NEW {9}
 β 3 class_fountain
 β 3 class_garbage_can
 β 3 class_gate NEW {4?, 5?}
 β 3 class_impassible (formerly fence)
 β 3 class_keyring NEW {2}
 β 3 class_light (formerly floor_lamp, street_lamp, flashlight)
 β 3 class_pond
 β 3 class_textured_polygon (formerly trapezoid & super_trapezoid){6}
 β 3 class_window
 λ class_bed
 λ class_bureaucrat {3}
 λ class_changomatic
 λ class_compass
 λ class_crystal_ball {3}
 λ class_die
 λ class_drugs
 λ class_escape_device
 λ class_flag
 λ class_game_piece
 λ class_hot_tub
 λ class_magic_container {3}
 λ class_range_wepon (formerly gun)
 λ class_striking_wepon (formerly club and knife)
 λ class_stun_gun
 λ class_throwing_toy (formerly ball and frisbee)
 τ class_animal (formerly house_cat)
 τ class_aquarium
 τ class_fake_gun

τ class_fortune_machine
 τ class_hole
 τ class_magic_lamp {3}
 τ class_sensor
 τ class_shovel
 τ class_ticket
 τ class_vendo_loader NEW {3}
 τ class_wind_up_toy
 ∂ class_binding_machine NEW {3}
 ∂ class_bottle
 ∂ class_clothing (NEW ?)
 ∂ class_external_interface NEW
 ∂ class_grenade
 ∂ class_hand_of_god
 ∂ class_movie_camera
 ∂ class_stocks
 ∂ class_text_pad (HTML) NEW
 ∂ class_tv (Video interface) NEW
 ∂ class_xerox_machine NEW
 class_bridge
 class_coke_machine
 class_dropbox
 class_mailbox
 class_matchbook

Realms:

The Argo & Promenade

- β The Argo
 - β Parrot
 - β Tokens
 - β Newsstand
- β The Promenade
 - β A Nu-Yoo
 - β Vendo
 - β Body change machine
 - β Heads and bodies
 - β Immigration Registration (name selection)
 - β Immigration Machine

The Downtown

- β Plaza
 - β Teleports
 - β Signs
- β Fountain
- β Shops
 - β Nu-Yoo
 - β Clothing
 - β Pawn
 - β Magic
 - β Banks
- λ Administration
 - λ Visitors bureau (help desk near the promenade)
- λ Auditorium
- λ Arcade
- λ Library
- λ Night life
- λ Club halls

λ Morpheus' Temple (Oracles' hang out)
λ Sewers.

The Dwellings

λ Turfs
λ Meeting Rooms
λ Common areas
λ Elevators

The Outer City

τ The Morpheus Gate
τ Topiary Maze.
τ Worm Maze.
τ More sewers.

The Wilderness

τ Private regions (waterfall: ambient sound)
τ Non-traditional dwellings (Tree houses, Caves)

∂ The First Working Gate (?)

Gestures:

α 1. Happy
α 2. Glad
α 3. Mad
α 4. Sad
α 5. Jump
α 6. Wave
β 7. Stamp foot (alternates feet)
β 8. Bend over (alternates with Bend back)
β 9. Shoulders up
β 10. Hand out

Commands with important gestures.

β Touch
β Punch
β Sit on floor

α9 realms:

State of the World
Alpha 9
1/16/95

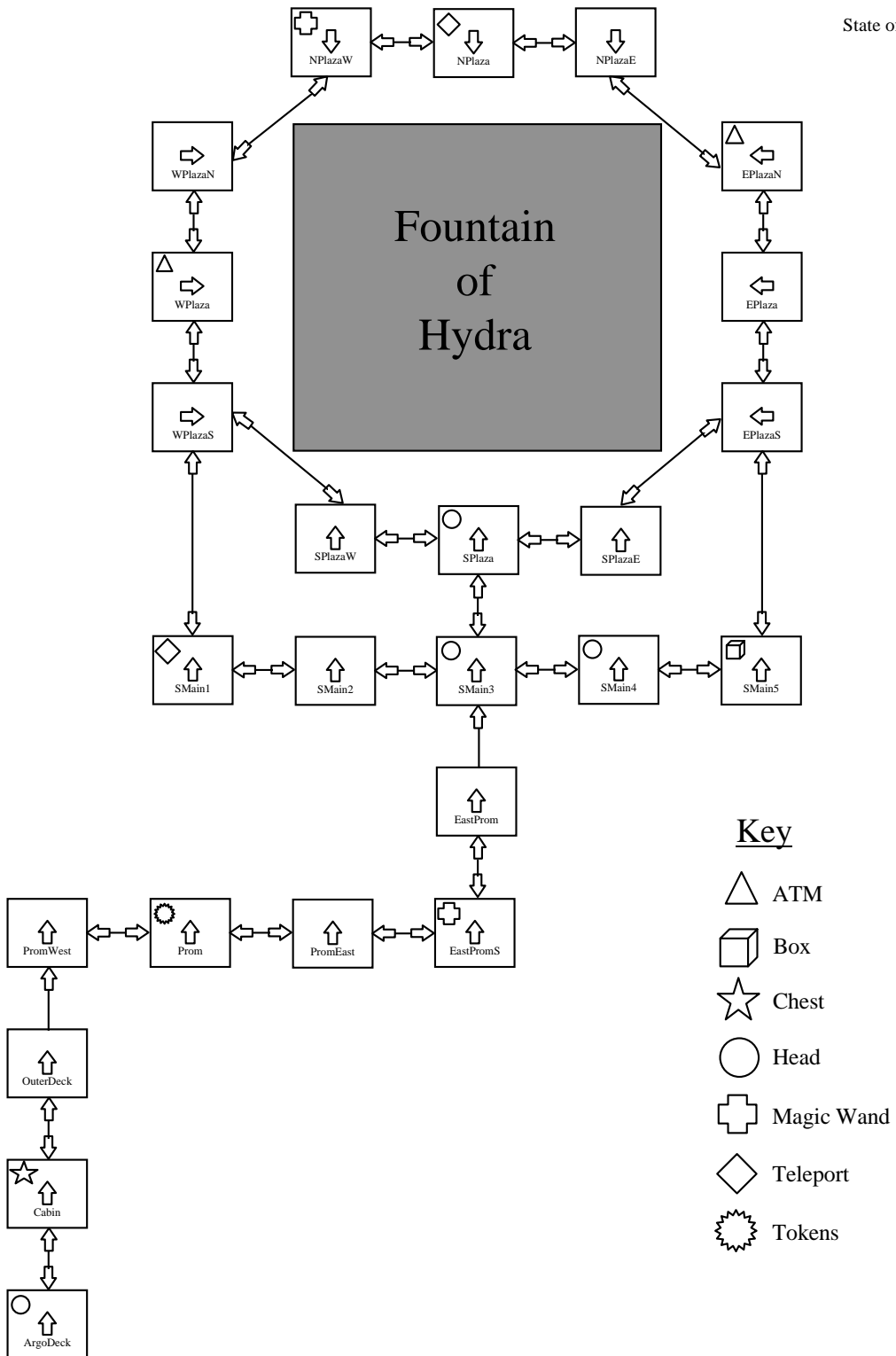

Objects: Objects are placed for testability, not functional layout.

Artwork: Artwork is limited. There is only one floor and one sky. There is only one graphic for each of the classes (see key, above).

β realms:

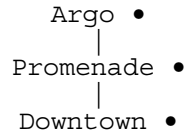

• = Early version
 + = Final version

Argo • is:

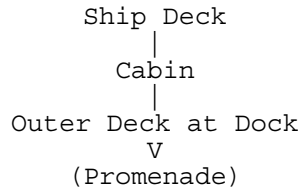

Promenade • is:

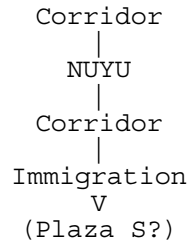

Downtown • is:

- = : Street (Building Front)
- . : Fountain region (Impassable)
- P : Plaza (Fountain View)
- B : Building Interior
- T : Telport

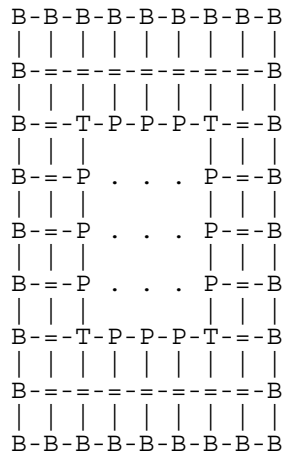

λ realms:



τ realms:

